

Driving Large Scale LED Panels Efficiently

Parallel to the introduction of LEDs for different lighting applications, critical voices argue that due to lowered energy consumption new applications could be introduced and a change in user behavior could lead to excessive use of LED based lighting products during the day, for example, for advertisements. This would cause the predicted hopes for overall energy saving due to LED technology to fail. It seems that this scenario is partially true. Therefore any amount of additional efficiency gain is well worth considering. K.H. Loo, Y.M. Lai, and C.K. Tse from The Hong Kong Polytechnic University examine and propose a new driving approach to achieve energy savings.

Figure 1:
Typical PWM (a)
and MPWM (b)
current waveform

Nowadays, large-scale LED display panels of various shapes and sizes have become a common feature in modern architecture and interior design. LED display panels can be found on outdoor billboards, in commercial buildings and public facilities for advertisements and information display. These panels typically operate for long hours and consume a large amount of electrical power. In some applications, they are even required to remain visible during daylight and thus are designed to deliver light output at high intensity that further increases their power consumption. A reduction of power consumption or an improvement in power efficiency, therefore, becomes a critical design issue of LED display panels for both reduced energy cost and environmental friendliness.

An Alternative LED Driving Approach

Since a large amount of the total power consumption of LED display panels occurs in the LED pixels, driving them efficiently has become a potential area for energy saving. Due to its format compatibility with the input video signal, PWM (pulse-width modulation) method is adopted for driving the individual LED pixels. With the PWM driving method, a constant DC current is applied to a given LED pixel over a duration known as the ON time, or t_{on} , and the current is removed over a duration known as the OFF time, t_{off} . By using the ON and OFF times, the dimming frequency f_{dim} is defined as $1/(t_{on} + t_{off})$, and the dimming duty cycle D as $t_{on}/(t_{on} + t_{off})$. By driving an LED pixel using PWM current, its light intensity can be varied by adjusting the dimming duty cycle as represented by the input video signal. When all LED pixels are driven similarly, textual or graphical information, and even motion pictures, can be formed and displayed by LED display panels.

Despite the advantages of linear dimming and format compatibility with video signal, LEDs illuminated by PWM current generally suffer from degradation in luminous efficacy due to the nonlinearity in the light output characteristic of LEDs, which causes more consumed power to turn into wasteful heat [1]. Not only that this will

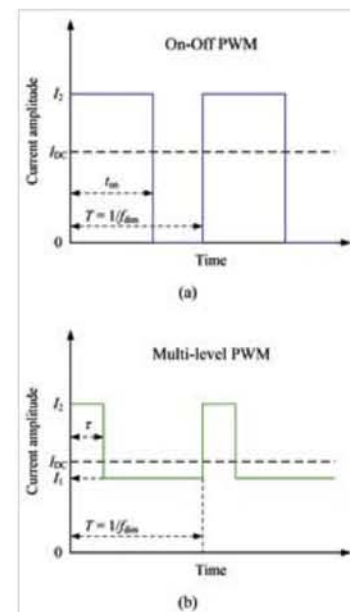

increase the power consumption of LED display panels for attaining a given intensity level, it will also lead to an increase in heat dissipation and a more expensive thermal design. Figure 1(a) shows the typical PWM current waveform having an average value of $I_{ave} = DI_2$; when I_2 is fixed, the average current or the pixel's intensity can be varied by adjusting D . The resulting light output characteristic of a typical LED pixel driven by PWM current resembles the blue dotted line shown in figure 2. For a given average current, the difference between the

Figure 2:
Light output characteristics under three driving methods

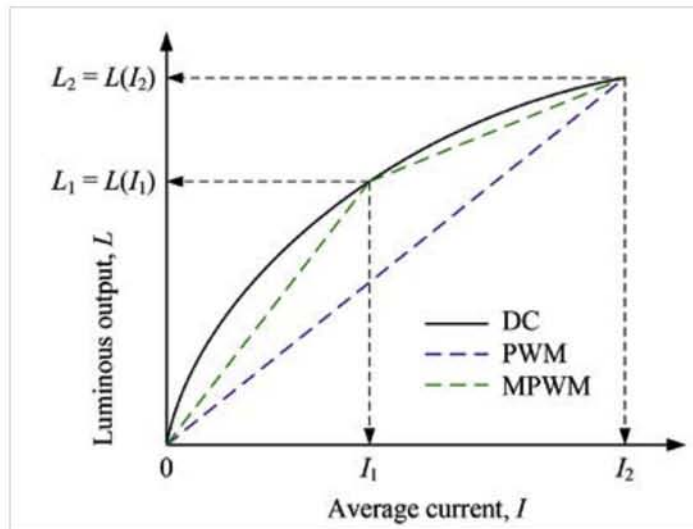

solid black curve and the blue dotted line represents the efficacy loss due to PWM driving.

It has been discovered that by adding current level(s) between I_2 and 0, part of the efficacy loss due to PWM driving can be compensated [2]. An early implementation of this driving approach used one extra current level I_1 between I_2 and 0, forming the bi-level current [2], and it was later generalized to an arbitrary number of current levels forming the multi-level PWM (MPWM) current [3]. Figure 1(b) shows a three-level MPWM current waveform and figure 2 shows its piecewise-linear light output characteristic as the green dotted line. It is clear that MPWM driving gives a higher light output compared to PWM driving with the same average current.

Interestingly, by referring to figure 1(b), the MPWM current can be thought of being the superposition of two PWM currents, one occurring between I_1 and 0, and the other one occurring between I_2 and I_1 , which explains the existence of two piecewise-linear sections in the light output characteristic under MPWM driving.

A Cost-Effective Implementation without System Redesign

The basic PWM-based architecture of a typical FPGA (Field-Programmable Gate Array)-controlled LED display panel system (Figure 3) consists of four main components, namely, the HDMI/DVI video signal decoder, FPGA controller, external RAM, and the LED display module. As the HDMI/DVI video

signal cannot be displayed directly on the LED display module due to format incompatibility, it is required that the video signal is first converted into 24-bit RGB signal, where the intensity of each color is coded with 8 bits, thus allowing the display of 256 intensity levels per color. The decoded 24-bit video signal is transmitted in parallel to the FPGA controller where the bit values having the same weight are grouped together. For example, all data bits corresponding to the weight of $2^3 = 8$ are grouped together and transmitted to the LED driver module in one batch, which will illuminate the LED pixels for $8/256$ of the line scan period.

Although, in theory, the number of intermediate current levels between I_2 and 0 can be arbitrarily many, the choice of one additional current level, thus forming a three-level MPWM driving scheme, is a reasonable one given the proportional increase in system complexity and cost despite the diminishing percentage gain in luminous efficacy with the increasing number of intermediate current levels. It is also necessary to maintain the light output characteristic as linear as possible.

To implement a three-level MPWM driving scheme on LED display panels, two LED driver modules can be connected in parallel to provide two constant-current drivers. It can be easily shown that the percentage gain in luminous efficacy is the maximum when each LED driver module delivers $I_1 = 0.5 \cdot I_2$ [5], and the corresponding three current levels are 0, I_1 , and $2 \cdot I_1$. Although the number of LED driver modules used is doubled in this case compared to the conventional PWM-based system, the additional hardware cost incurred is not doubled given that IC manufacturers can redesign the existing LED driver module ICs to house multiple driver modules within one IC package.

With the use of two LED driver modules, two separate bit-streams are needed to activate them. In the modified system architecture (Figure 4), each of the two bit-streams is derived from the original input video signal that

Figure 3:
Conventional LED display panel system architecture

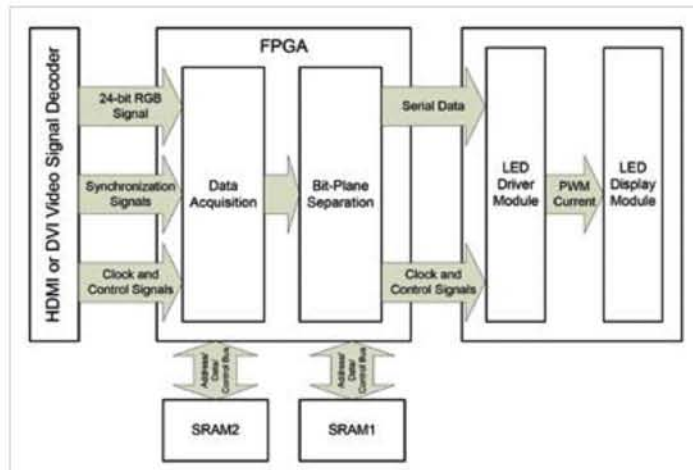
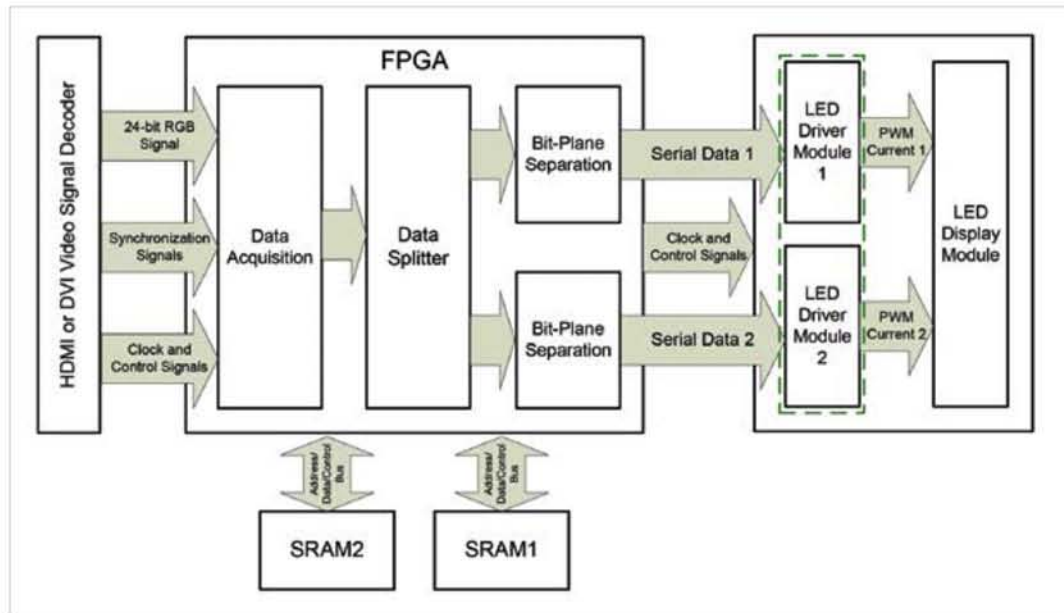

Figure 4:
Modified LED display panel system architecture for compatibility with MPWM driving



is turned into two sub-video signals by the data splitter unit in the FPGA. An example of data splitting is given here to illustrate the data conversion process. Suppose that the original input video signal is [1100 0101] in binary form, or [197] in decimal form, the equivalent duty cycle represented by this signal is $197/255$. In a PWM-based system, the desired average current is given by $I_{ave} = (197/255)I_2$. Since $I_2 = 2I_1$, I_{ave} can be rewritten as $I_{ave} = (394/255)I_1$, or

$(255/255)I_1 + (139/255)I_1$. Therefore, in a MPWM-based system, the same desired average current can be delivered by two LED driver modules, one delivering I_1 for the complete line scan period, and the other one delivering I_1 for 139/255 of the line scan period. For the first LED driver module, the FPGA will output an 8-bit data stream of [1111 1111] (= 255), and for the second LED driver module, the FPGA will output [1000 1011] (= 139). These simple arithmetic

calculations can be implemented easily on the FPGA controller with no additional cost.

In a prototype of LED display panel (Figure 5) assembled with 2×3 display modules, the upper row (containing three display modules showing blue, green, and red color, respectively) is driven by PWM current, whereas the lower row is driven by MPWM current having the same average value as the PWM current. The differences between the two driving approaches in the generated light intensities for all three colors are clearly visible from the figure. To give a more quantitative comparison between them, the generated light intensities by the two driving approaches were measured for each color over the full range of average current (from 0 to 255) and the results are plotted (Figure 6). For all three colors, MPWM driving consistently produces higher light intensities, as expected from the previous analysis on LED's nonlinear light output characteristic. The piecewise-linear sections in the light output characteristic resulting from MPWM driving are also evident from the figure. On average, the percentage gain in luminous efficacy over PWM driving is 12% for blue, 14% for green, and 10% for red, respectively.

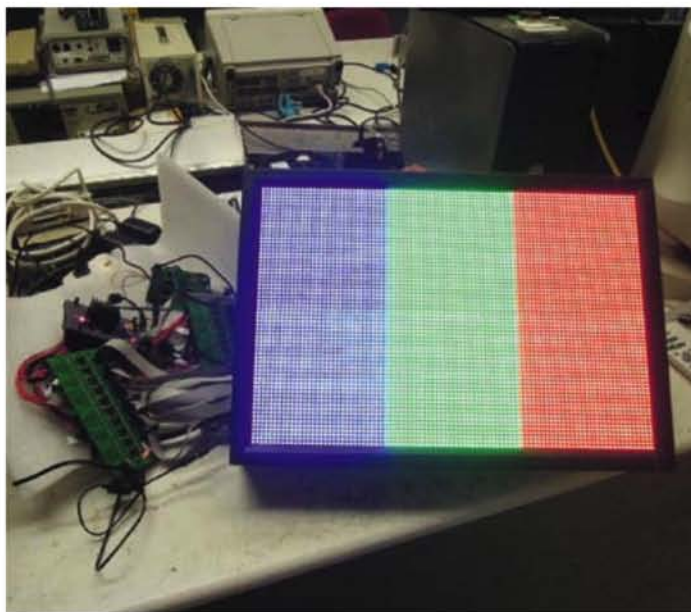

Figure 5: Prototype of an LED display panel with 2×3 display modules

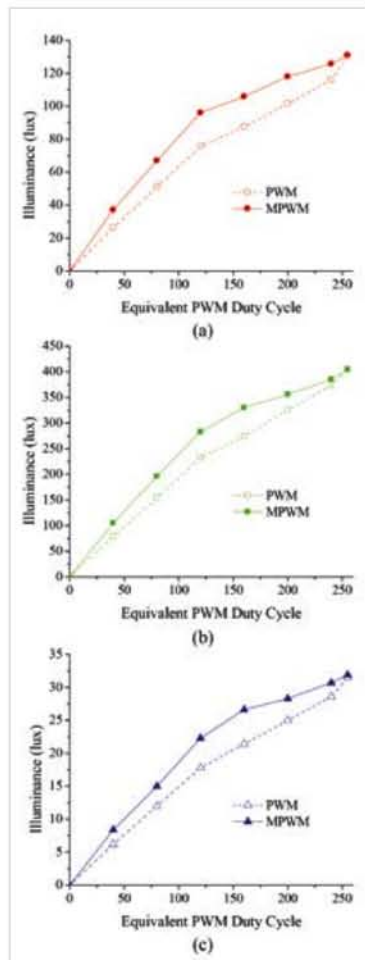

Figure 6: Measured light intensities generated by PWM and MPWM driving approaches for all three colors (RGB)

Conclusions

With the introduction of LEDs and the related new opportunities, display panels of various shapes and sizes have become more popular. Early studies predicted that such applications and the usage under daylight conditions might become common practice. The high necessary light output leads to corresponding high energy consumption. An intelligent driver design can increase system efficiency notably. It could be demonstrated that the proposed solution leads to an average energy saving of 12% in RGB billboard systems without compromising functionality, thus making such applications more environmentally friendly. ■

References:

- [1] K.H. Loo, W.K. Lun, S.C. Tan, Y.M. Lai, C.K. Tse, "On Driving Techniques for LEDs: Toward a Generalized Methodology," *IEEE Transactions on Power Electronics*, Vol. 24, No. 12, pp. 2967–2976, 2009
- [2] W.K. Lun, K.H. Loo, S.C. Tan, Y.M. Lai, C.K. Tse, "Bilevel Current Driving Technique for LEDs," *IEEE Transactions on Power Electronics*, Vol. 24, No. 12, pp. 2920–2932, 2009
- [3] S.C. Tan, "General n-Level Driving Approach for Improving Electrical-to-Optical Energy Conversion Efficiency of Fast-Response Saturable Lighting Devices," *IEEE Transactions on Industrial Electronics*, Vol. 57, No. 4, pp. 1342–1353, 2010
- [4] Data Sheet, MBI5020: 16-bit Constant Current LED Sink Driver, Macroblock Inc., 2003
- [5] X. Lv, K.H. Loo, Y.M. Lai, C.K. Tse, "Energy-Saving Driver Design for Full-Color Large-Area LED Display Panel Systems," *IEEE Transactions on Industrial Electronics* (in press) (Document DOI 10.1109/TIE.2013.2288209)

Remarks:

1. The work had won the Gold Medal in the 41st International Exhibition of Inventions 2013, Geneva, Switzerland, 10–14 April 2013.
2. Full technical details of the technology described in this article can be obtained from reference [5], a journal paper published by the same authors.



BEYOND SAFETY

UL SERVICES AND EXPERTISE BRING NEW OPPORTUNITIES TO LIGHT

- Obtain Safety, Energy Efficiency, Performance Certifications and more
- Access Global Markets
- Leverage Industry Expertise and Standards Development
- Get a Type C Goniophotometer for Your Lab

DISCOVER MORE AT UL.COM/LIGHTING

LIGHT+BUILDING,
BOOTH #4.1–A15

LIGHTFAIR
INTERNATIONAL
UL BOOTH #5446



UL and the UL logo are trademarks of UL LLC © 2014 EOI 40132 LED's 02_14